

Advanced Rigging Calculations & Safety

Safe lifting is not just about equipment; it is about precision. This module covers the mathematical formulas, sling angle physics, and load estimation techniques required to approve complex lift plans.

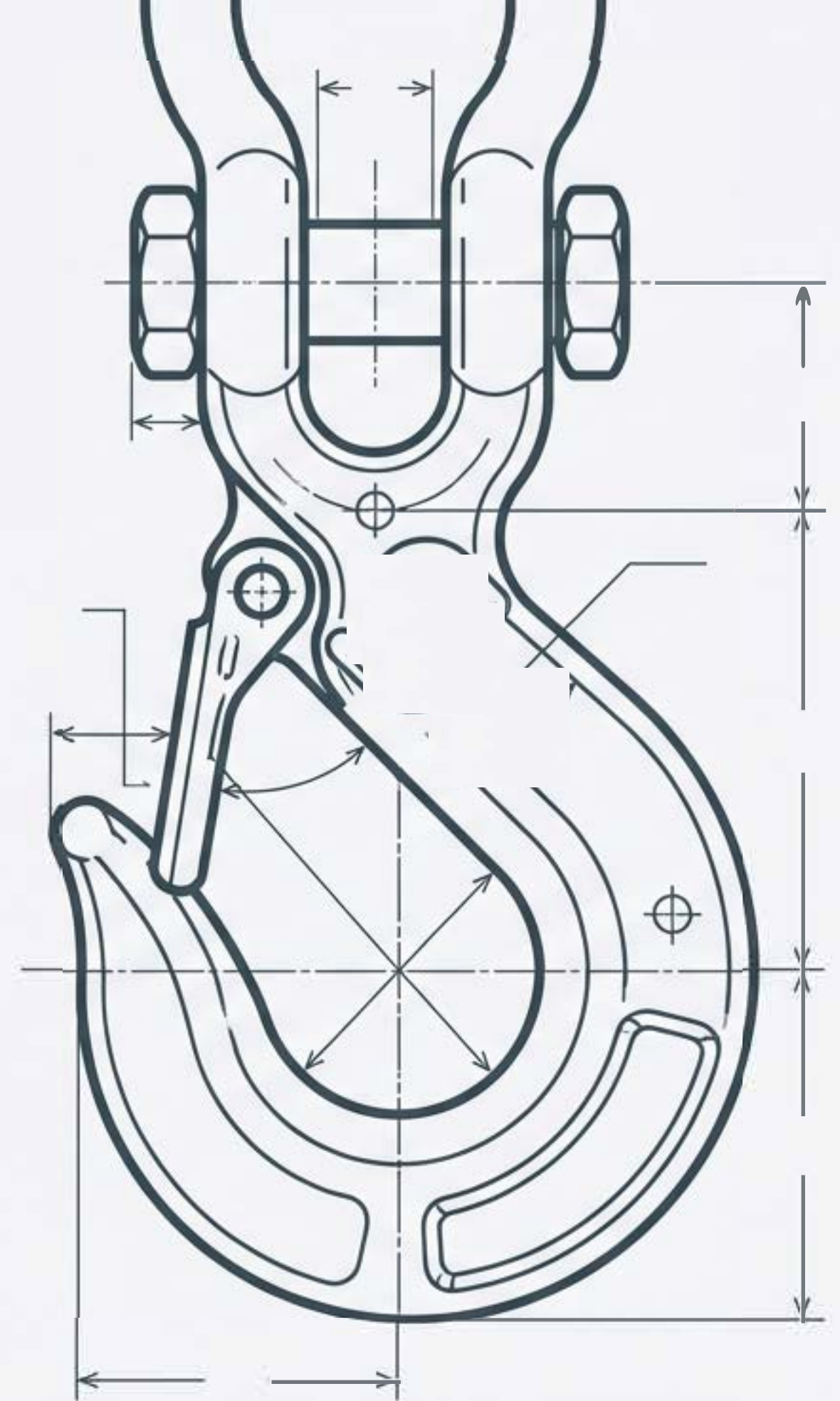

The Mandate: Responsibilities of Rigger 2



COMMUNICATION

Direct contact with crane operators via signals, radio, or weaseling.



INSPECTION

Mandatory verification of all riggings before use.

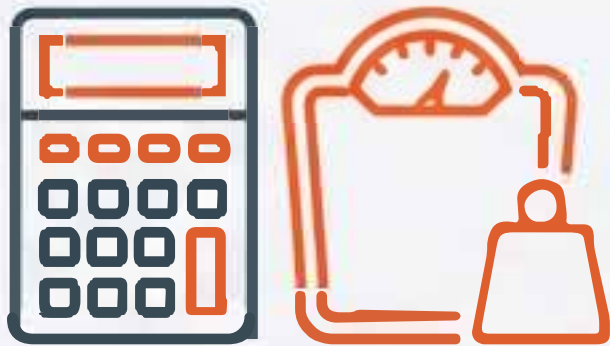

SELECTION

Authority to choose correct sling types and capacities based on calculation.



PLANNING

Responsibility to make and approve lifting plans, including tandem lifts.



2-Leg Lifts: The Multiplier Rules

As the horizontal angle decreases, tension increases. Use these factors to find SWL.

Included Angle: 60°	Horizontal Angle: 60°	Formula: Load × 0.6
Included Angle: 90°	Horizontal Angle: 45°	Formula: Load × 0.7
Included Angle: 120°	Horizontal Angle: 30°	Formula: Load × 1.0

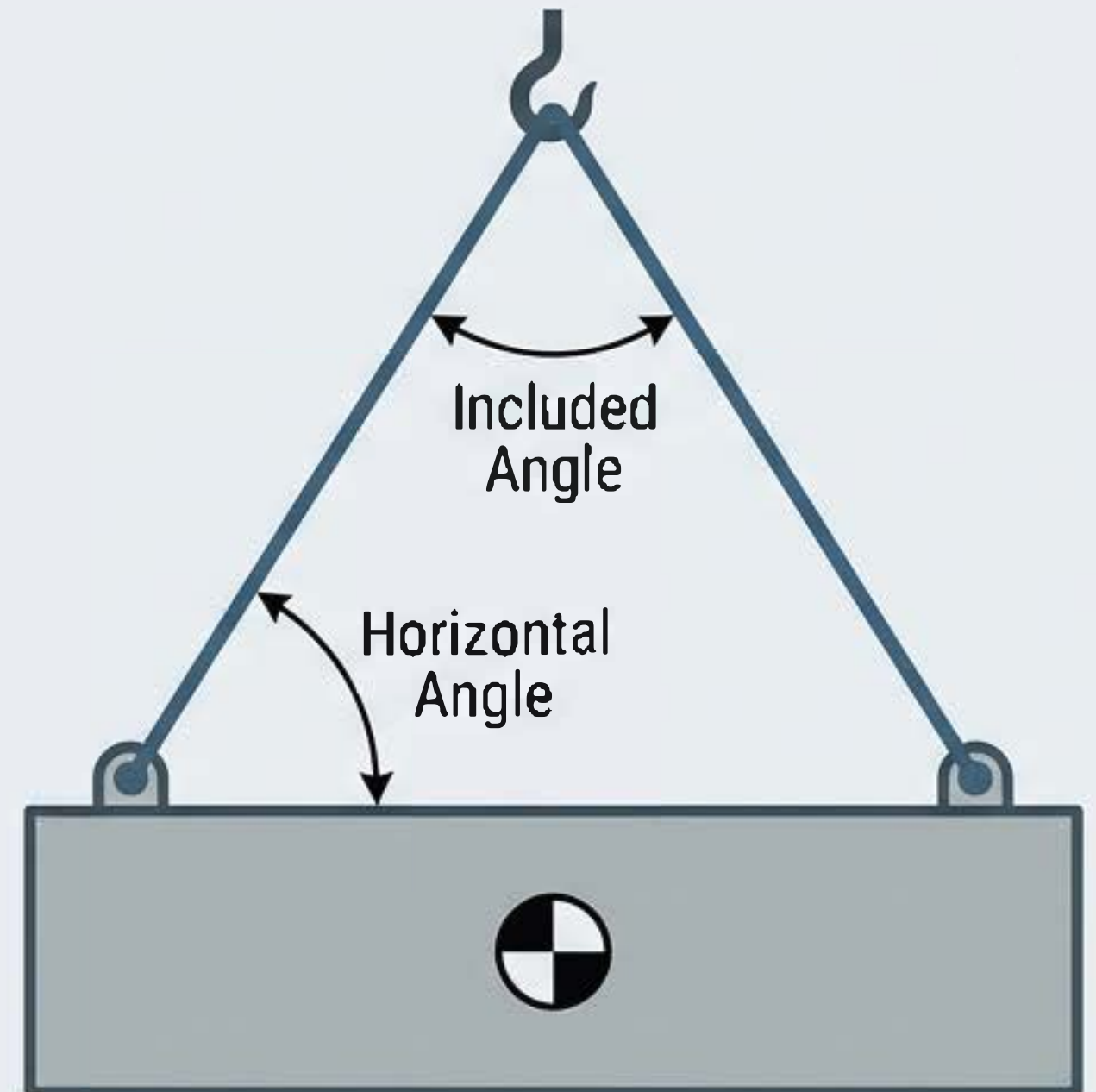

Field Estimation: Identifying Angles Visually

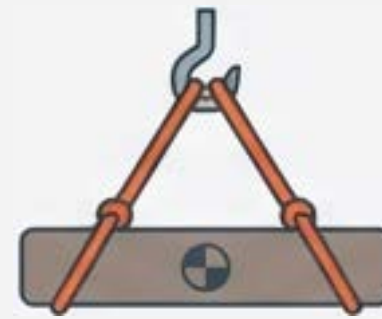
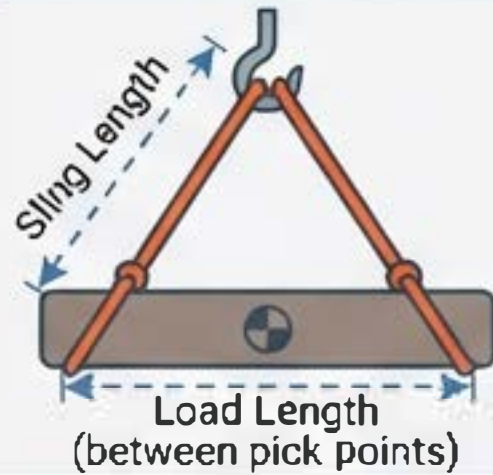

The 60° Rule

Sling Length = Load Length
(between pick points)

Multiplier: **0.6**

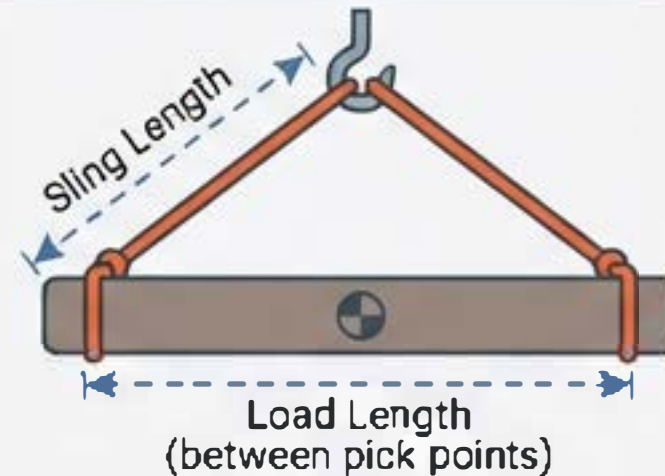
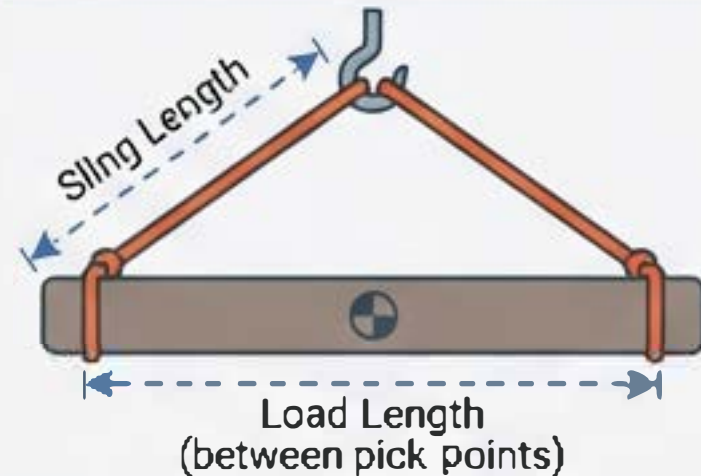

The 90° Rule

Sling Length \approx 71%
of Load Length

Multiplier: **0.7**

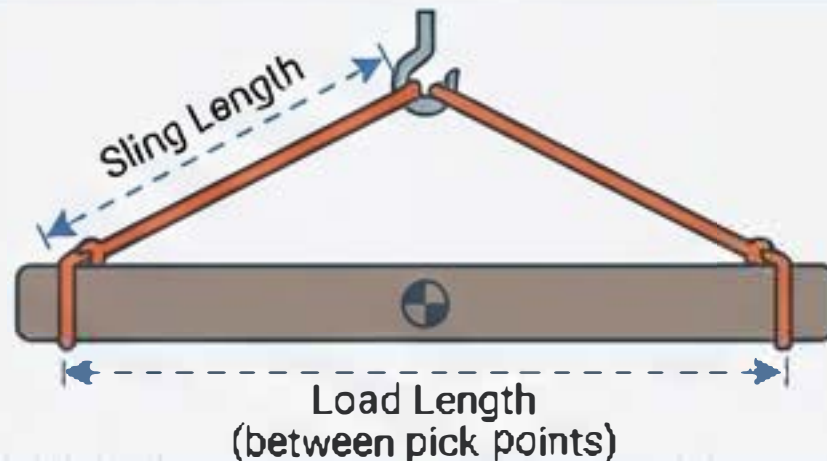

The 120° Rule

Sling Length \approx 58%
of Load Length

Multiplier: **1.0**

Multi-Leg Lifts (3 & 4 Legs)

Critical Adjustment: The Multipliers Change.

NOTE:

For 3 or 4 legs, the load distribution assumption changes. Do not use 2-leg factors.

Included / Horizontal Angle	Multiplier
$60^\circ / 60^\circ$	0.4
$90^\circ / 45^\circ$	0.5
$120^\circ / 30^\circ$	0.7

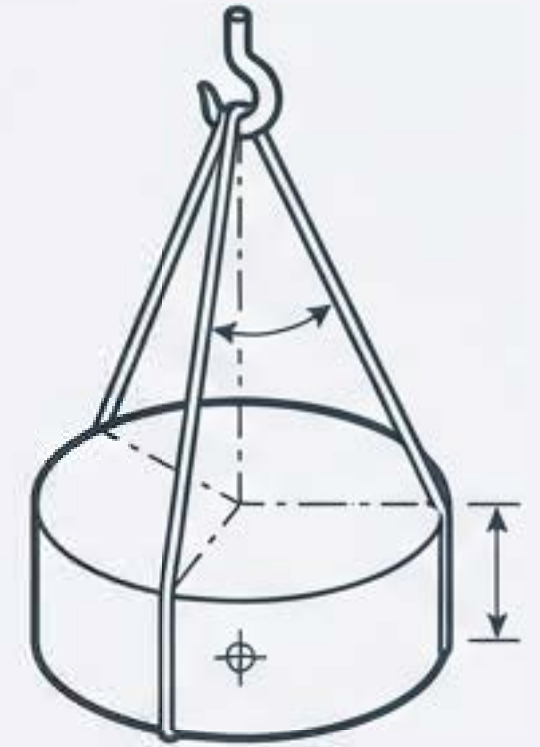

Three-leg lifts

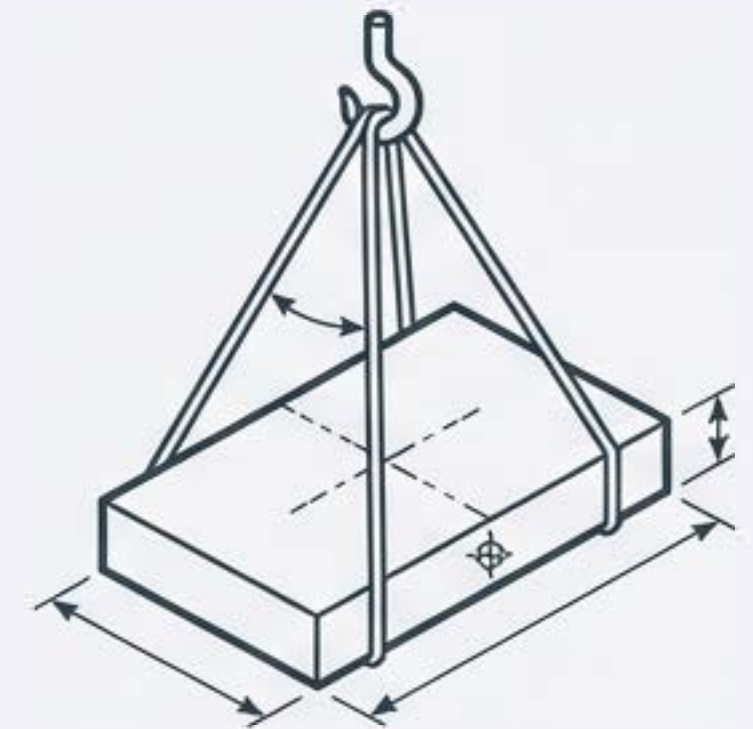

Four-leg lifts

Component Selection: Wire Rope Standards

Diameter (Inches)	Decimal Equivalent
1/2"	0.50
5/8"	0.625
3/4"	0.75
7/8"	0.875
1"	1.00
1 1/8"	1.125
1 1/4"	1.25
1 1/2"	1.50

HITCH CONFIGURATIONS & CAPACITY FACTORS

VERTICAL HITCH

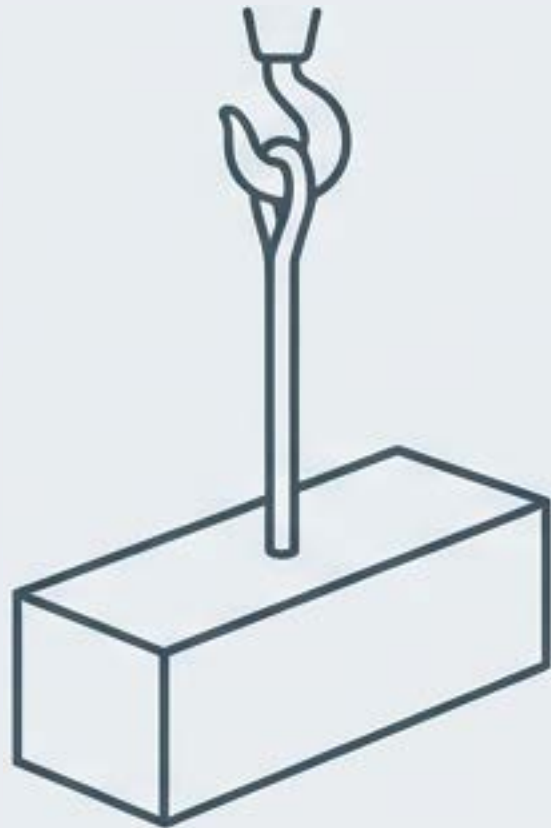

Capacity: 100%

$$\text{SWL} = \text{Load} / 1$$

CHOKER HITCH

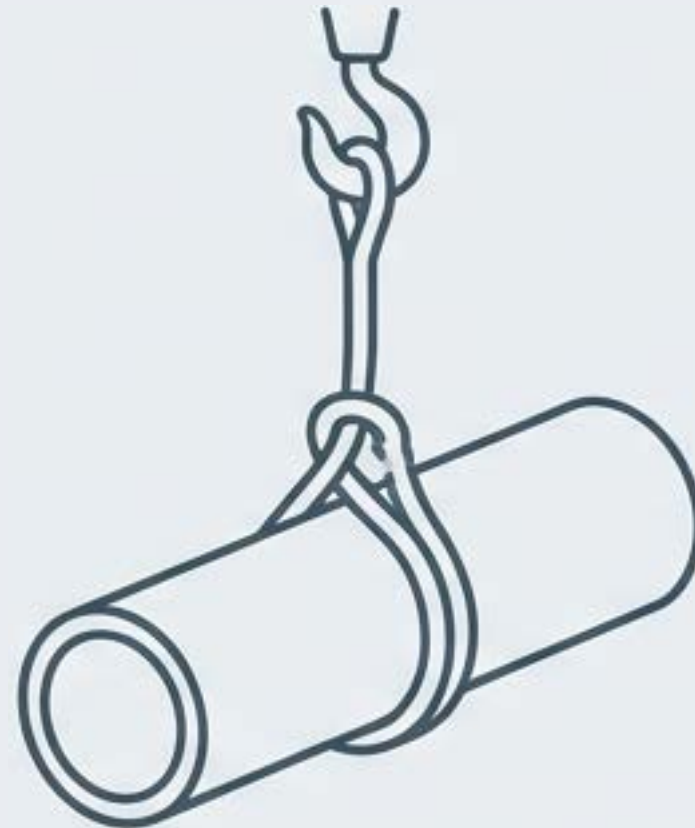

Capacity: 75%

$$\text{SWL} = \text{Load} / 0.75$$

The choker stress requires higher rated SWL.

BASKET HITCH

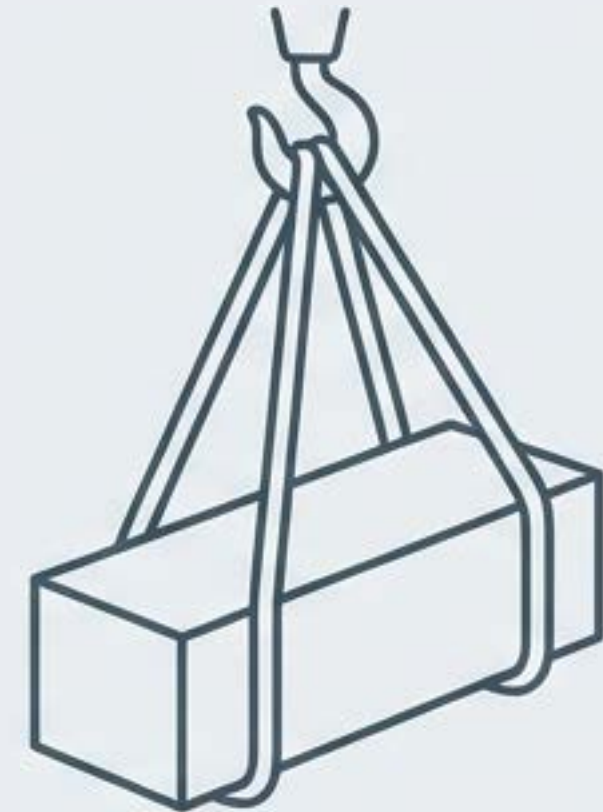

Capacity: 200%

$$\text{SWL} = \text{Load} / 0.5$$

Load distributed across two legs.

CASE STUDY: 16T LOAD (2-LEG LIFT)

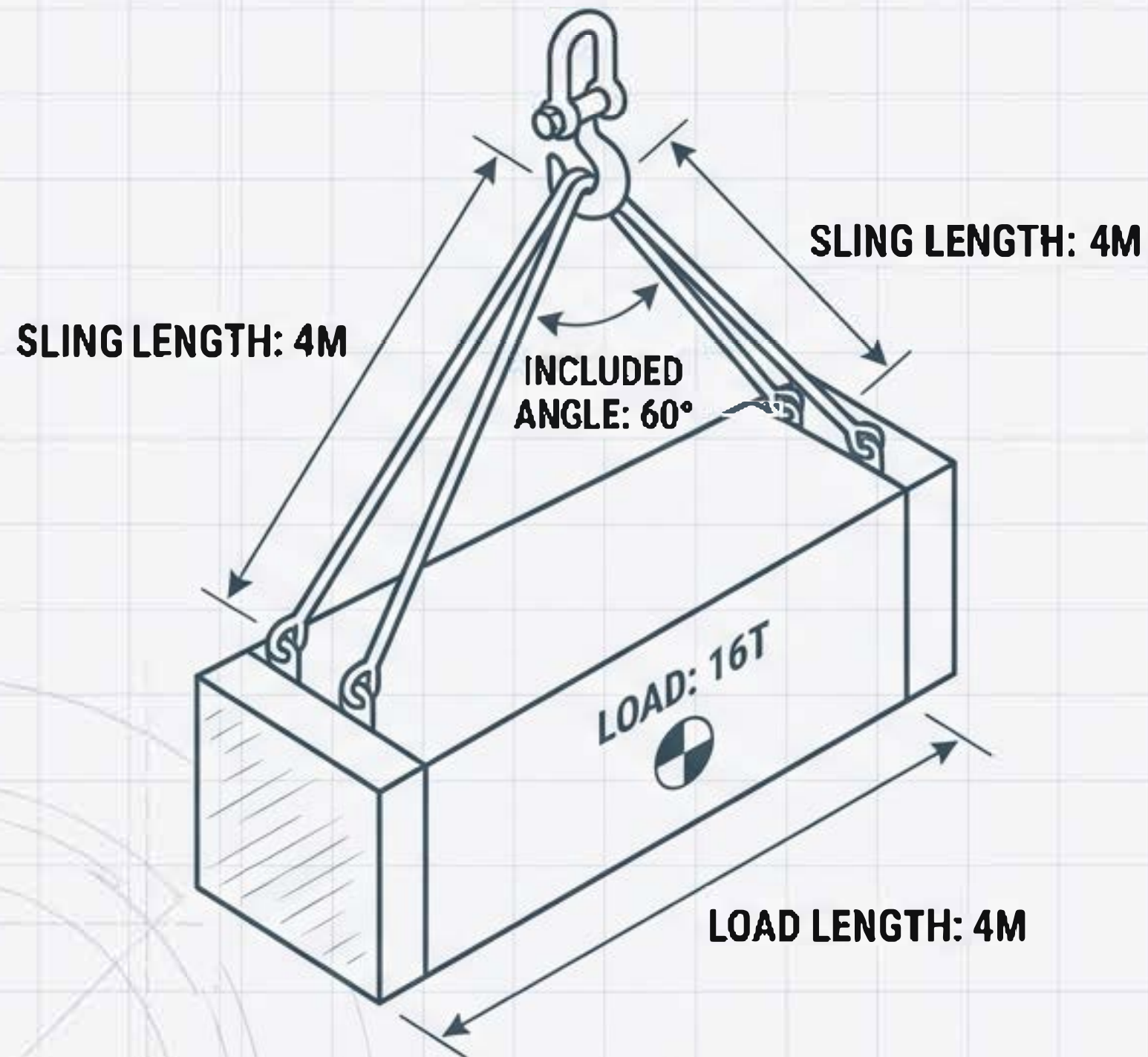

CALCULATION STEPS

Step 1:

- **Identify Angle:** Sling Length (4M) = Load Length (4M). Angle is 60°.

Step 2:

- **Select Multiplier:** At 60°, Multiplier = **0.6**.

Step 3:

- **Calculate SWL:** 16T × 0.6 = **9.6 Tons**.

REQUIRED SWL PER SLING: 9.6 TONS

CASE STUDY: SHORTENING THE SLINGS

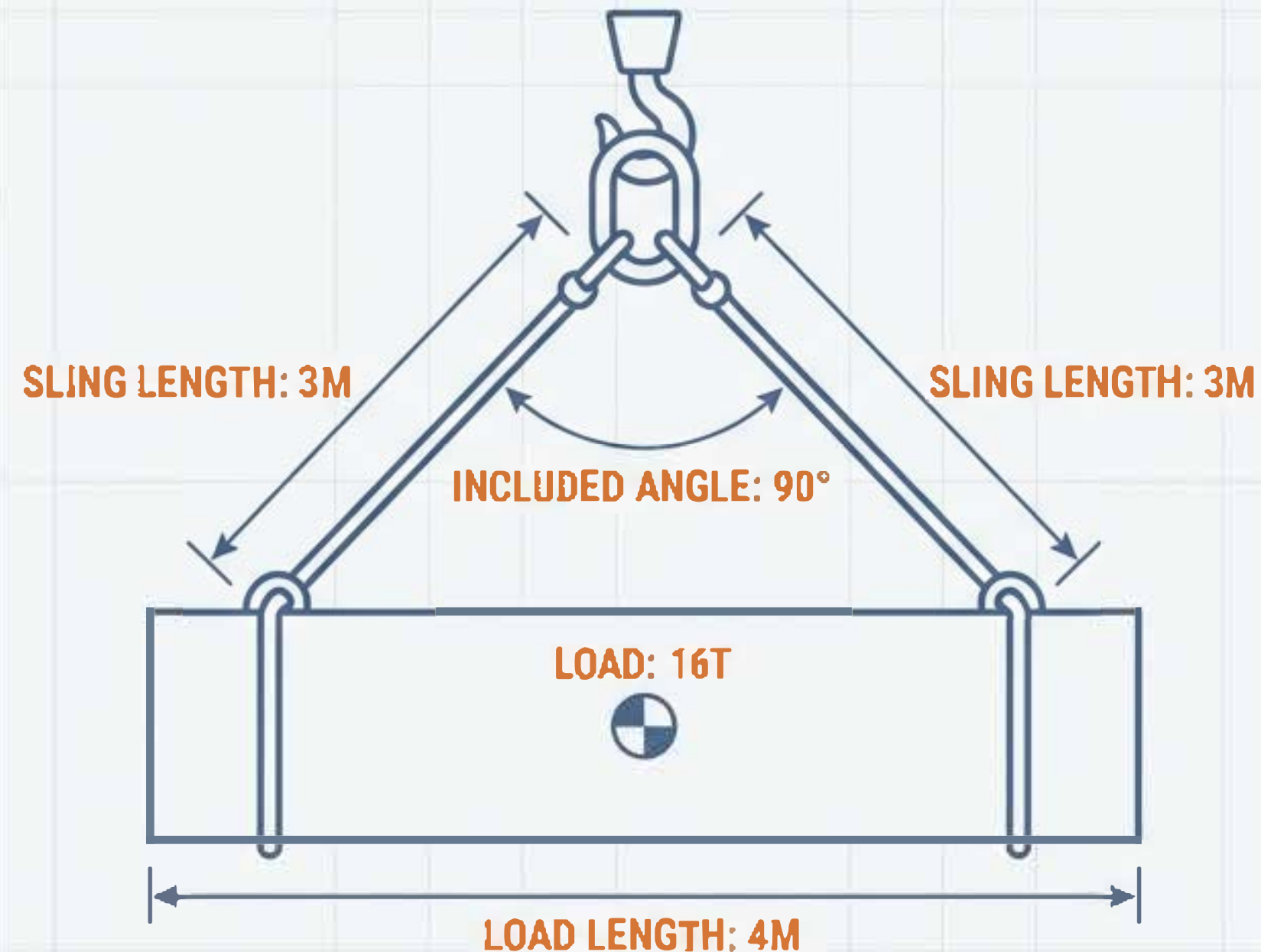

CALCULATION STEPS

Step 1: Identify Angle: 3M is $< 71\%$ of 4M.
Angle widens to 90° (Included).

Step 2: Select Multiplier: At 90° , Multiplier increases to 0.7.

Step 3: Calculate SWL: $16T \times 0.7 = 11.2$ Tons.

REQUIRED SWL PER SLING: 11.2 TONS

Insight: Shortening the sling from 4m to 3m increased the stress, requiring a stronger sling (11.2T vs 9.6T).

CASE STUDY: 20T LOAD (3 & 4 LEG LIFT)

SCENARIO A

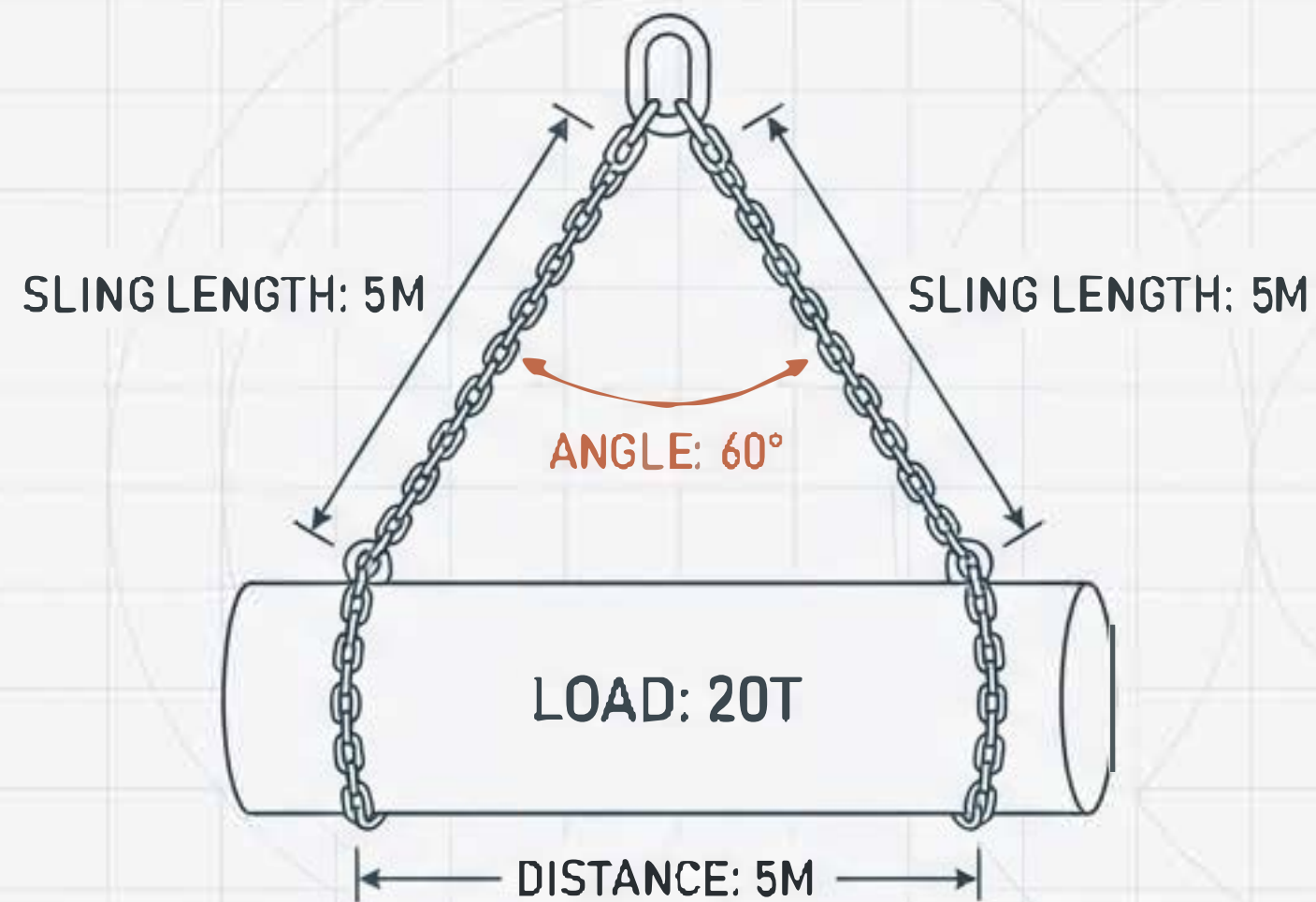

Angle: 60°

Multiplier Rule: 3/4 Legs @ 60° uses **0.4**

Calculation: 20T × 0.4 = **8 Tons.**

SCENARIO B

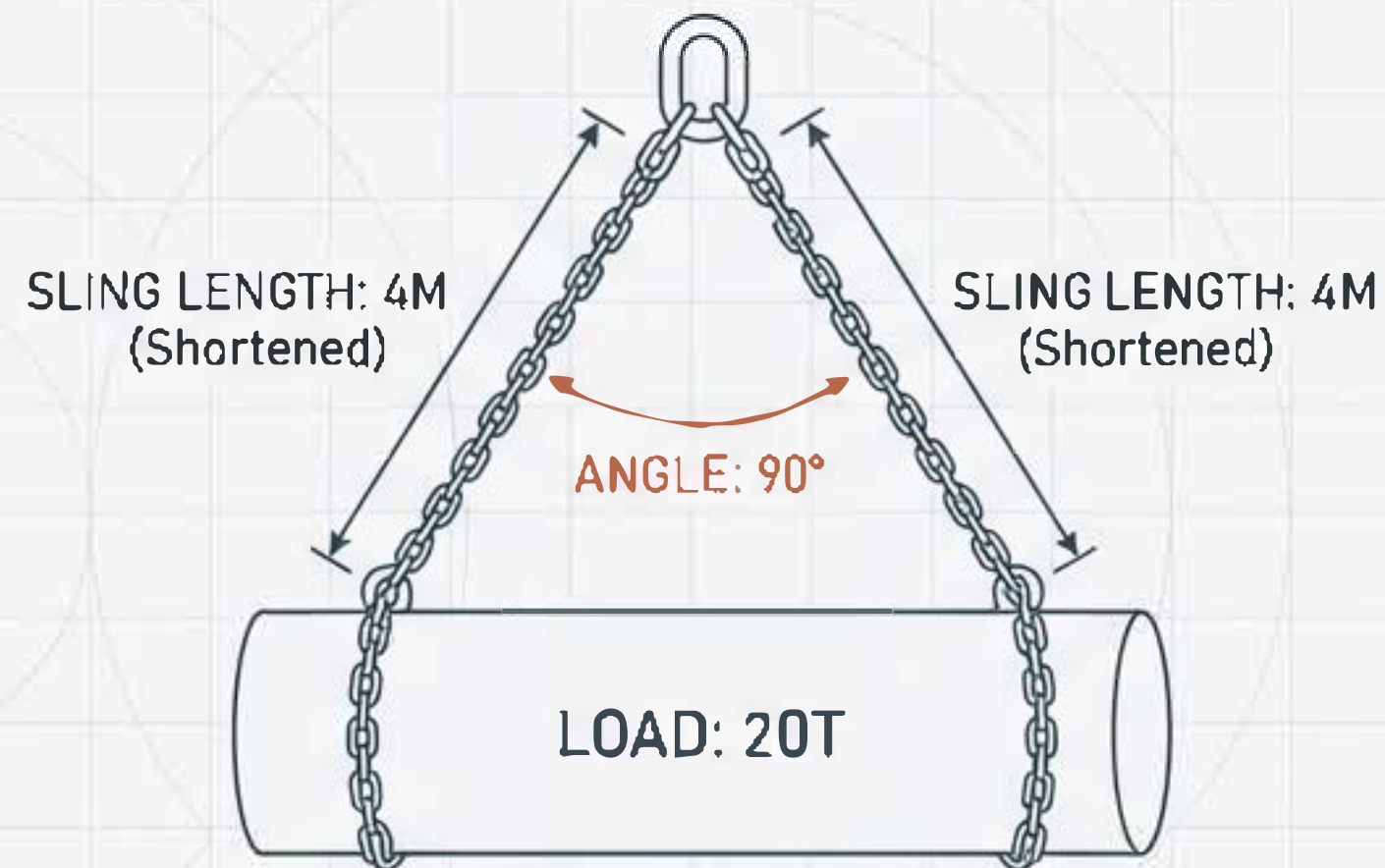

Angle: 90°

Multiplier Rule: 3/4 Legs @ 90° uses **0.5**

Calculation: 20T × 0.5 = **10 Tons.**

ESTIMATING LOAD WEIGHT: GEOMETRY

FORMULA: WEIGHT (W) = VOLUME (V) × DENSITY (P)

RECTANGULAR LOAD

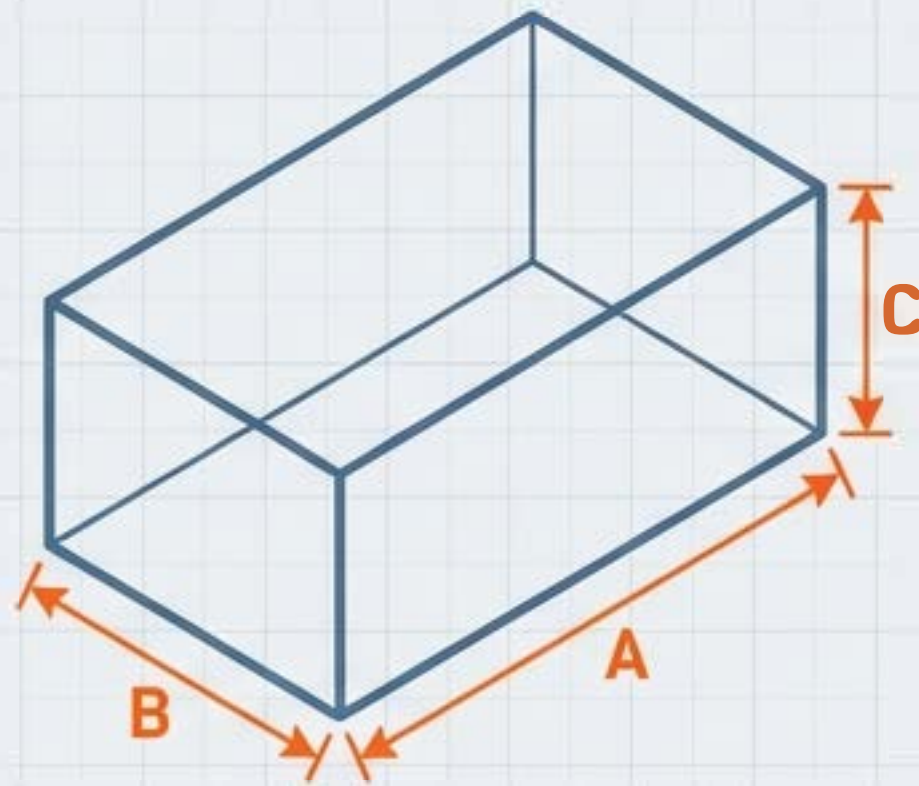

$$V = A \times B \times C$$

SOLID CYLINDER

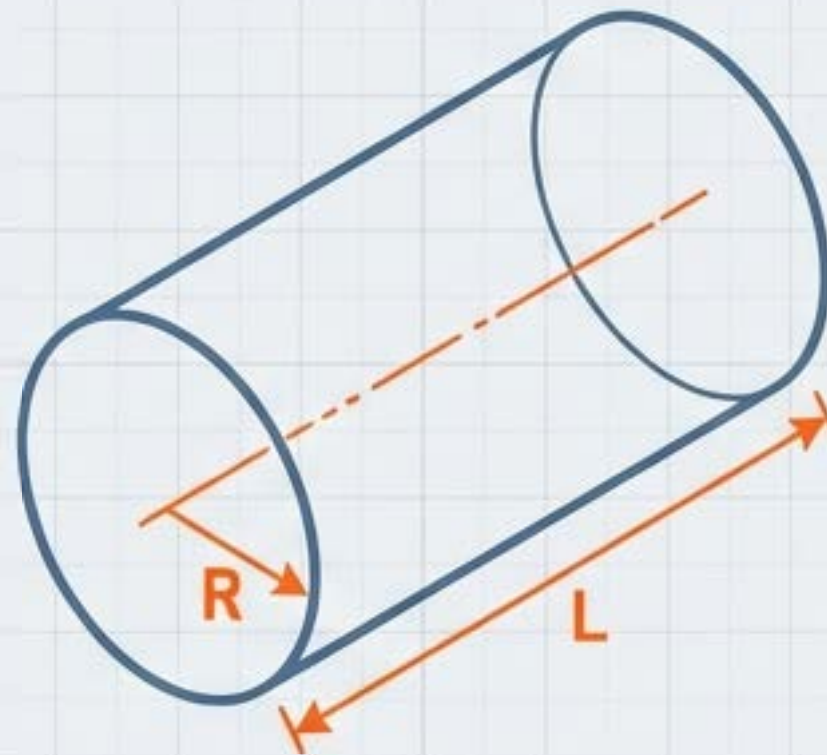

$$V = 3.14 \times R^2 \times L$$

HOLLOW CYLINDER (PIPE)

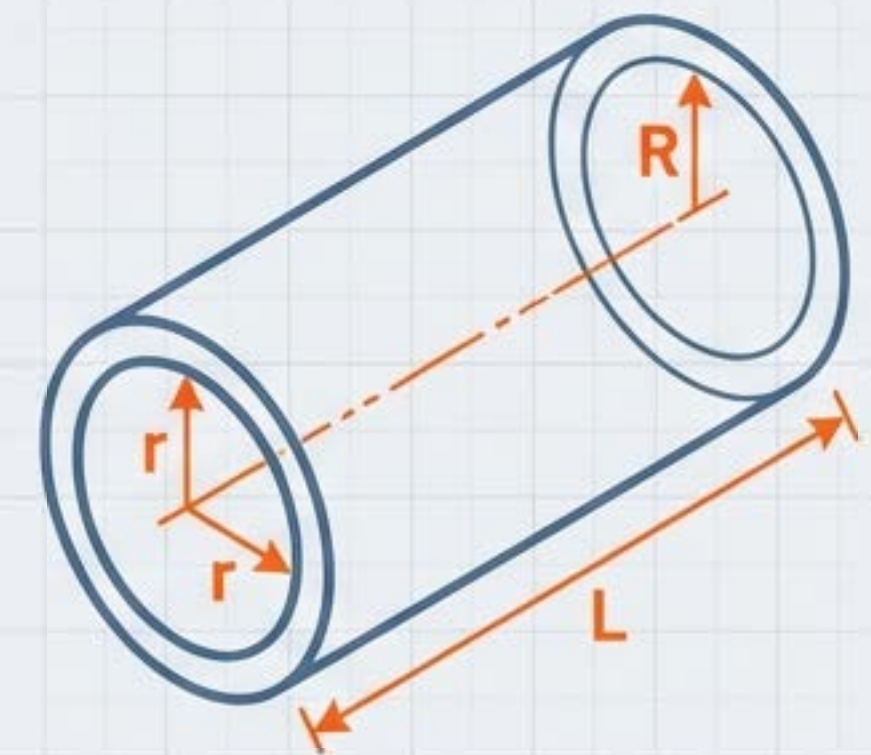

$$V = 3.14 \times (R^2 - r^2) \times L$$

ESTIMATING LOAD WEIGHT: MATERIAL DENSITY

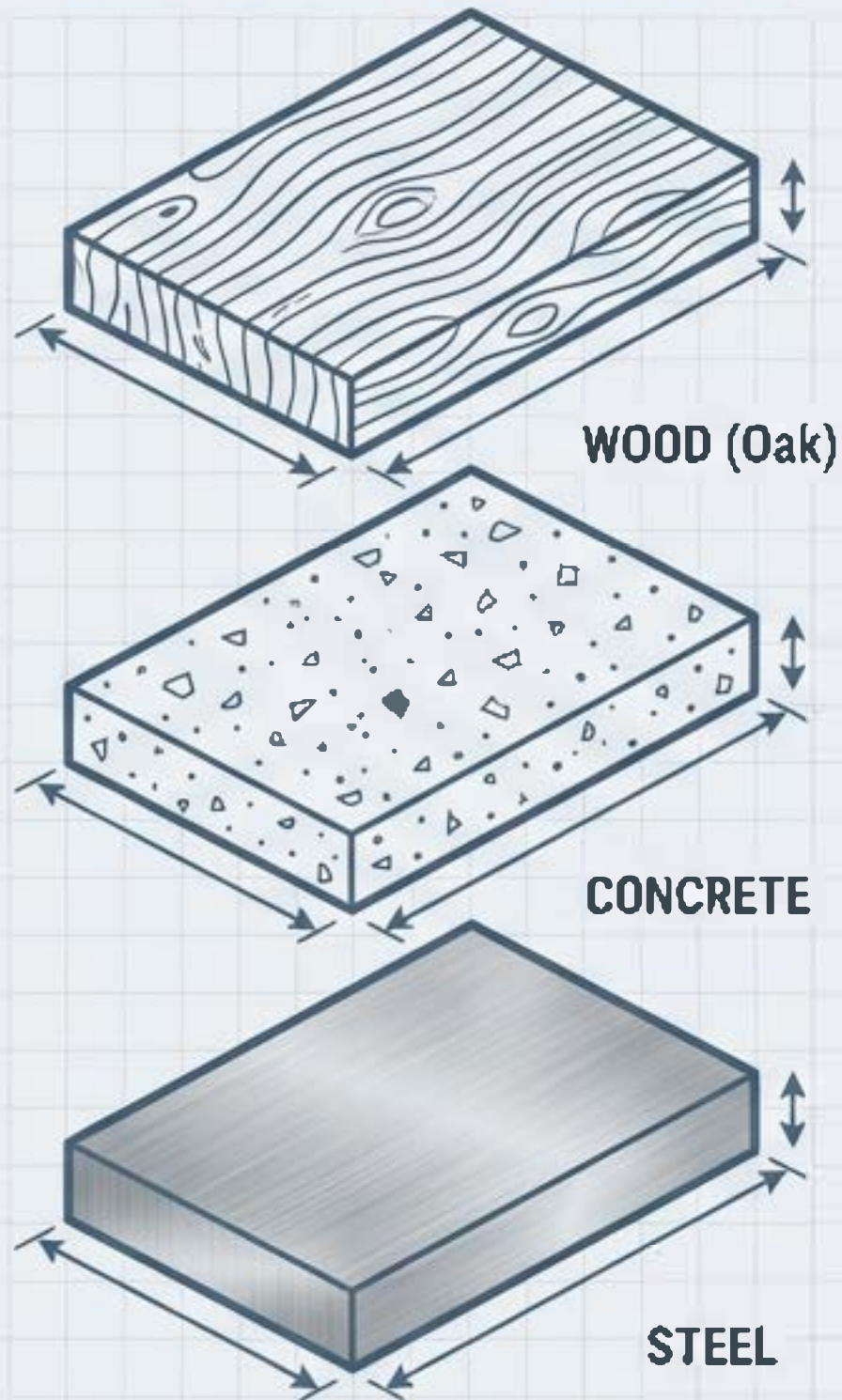

MATERIAL DENSITY (kg/m ³)	
MATERIAL	DENSITY (kg/m ³)
Steel	7850
Concrete	2400
Wood (Oak)	800 - 900
Water	1000
Aluminum	2700

VERIFICATION: A visually identical block of steel weighs approx. 3x more than concrete. Always verify material.

ADVANCED SCENARIO: THE LIFTING BEAM

STRUCTURAL ASSEMBLY & CALCULATION

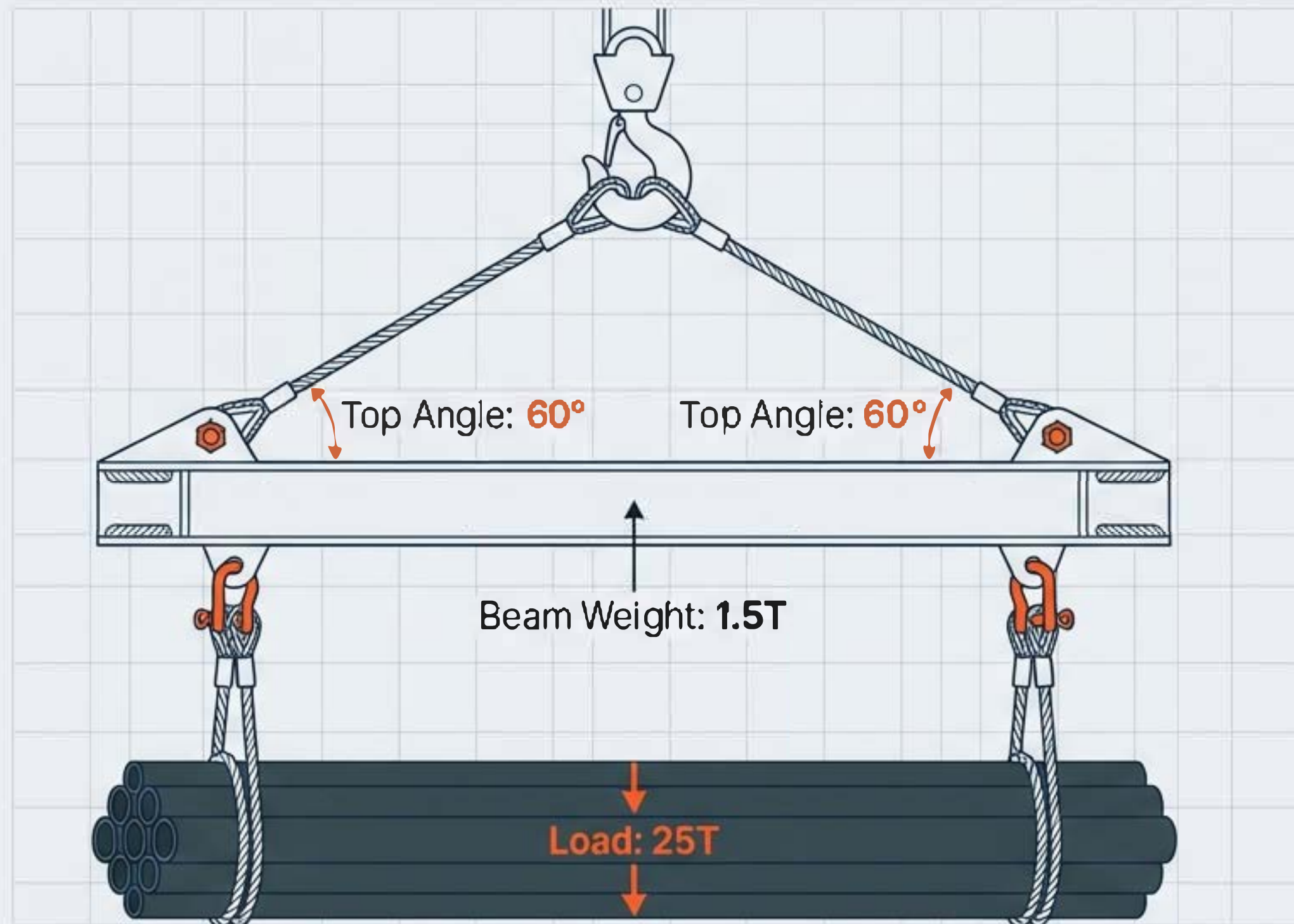

STEP 1: BOTTOM SLINGS

Lifting 25T Load vertically (2 legs). The load is shared equally between the two vertical slings.

$$\text{SWL} = \frac{25}{2} = \mathbf{12.5T} \text{ per sling.}$$

STEP 2: TOP SLINGS

Lifting Load (25T) + Beam (1.5T) = 26.5T Total.
Angle 60° from horizontal (Factor 0.6).

$$\text{Calculation: } 26.5 \times 0.6 = \mathbf{15.9T.}$$

Result: **Top slings must be rated for > 15.9T.**



HEAVY LIFT SCENARIO: 35T / 4 LEGS

STRUCTURAL ASSEMBLY & CALCULATION

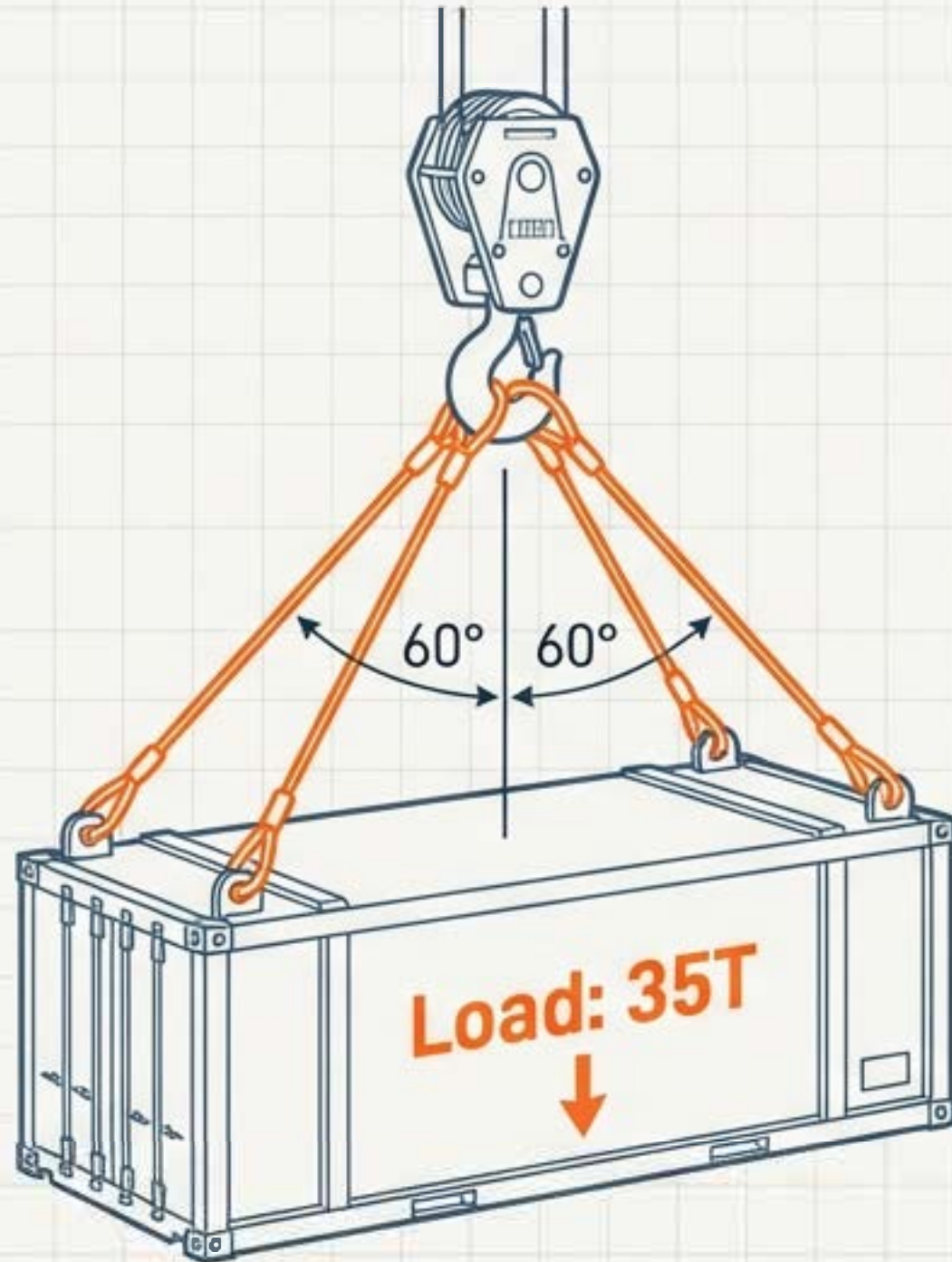

PROBLEM:

Load = 35T. 4 Legs. Angle = 60°.

CALCULATION RULE:

For 4 legs @ 60°, use Factor 0.4.

MATH:

$35T \times 0.4 = 14 \text{ Tons.}$

RESULT:

Required SWL per sling =

14 Tons.



THE SAFE LIFT PROTOCOL

